

Type	: High Temperature Rechargeable Nickel Metal Hydride Cylindrical Cell
Nominal Dimension (with Sleeve)	: $\Phi = 14.4\text{mm}$ H = 48.2mm
Applications	: Long term standby use. Recommended discharge current : 110mA to 550mA
Nominal Voltage	: 1.2V
Nominal Capacity	: Minimum: 1100mAh Typical: 1155mAh When discharged at 220mA to 1.0V at 20
Charging Condition	: Standard mode : 110mA for 16 hrs at 20 Standby Intermittent model: 110mA for 16hrs at 20 . then maintenance with 110mA for 1min/ 10mins.
Service Life	: >350 cycles (IEC 61951-2) Designed for a 10 years standby life, end of life capacity is 60% of nominal capacity .
Continuous Overcharge	: Comply with IEC61951-2 Permanent Charge Endurance Test
Weight	: 21.5g
Internal Resistance	: Average 23m Ω upon fully charged (Range 18 - 28m Ω) at 1000Hz
Max. Charging Voltage	: 1.5V at 110mA charging
Ambient Temperature Range	: Charge : 0 to 40 Discharging : -20 to 40 Storage : -20 to 35 Storage (1 week) : -20 to 60

Model No.: GP110AAHT

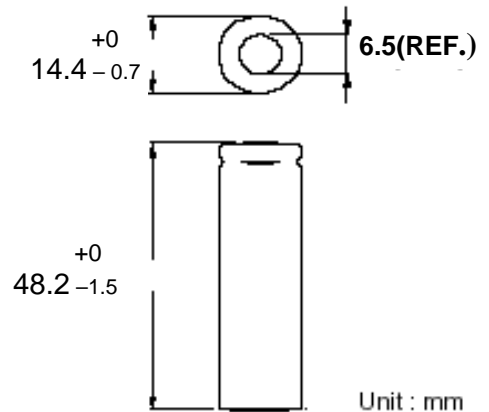

Low Rate Discharge

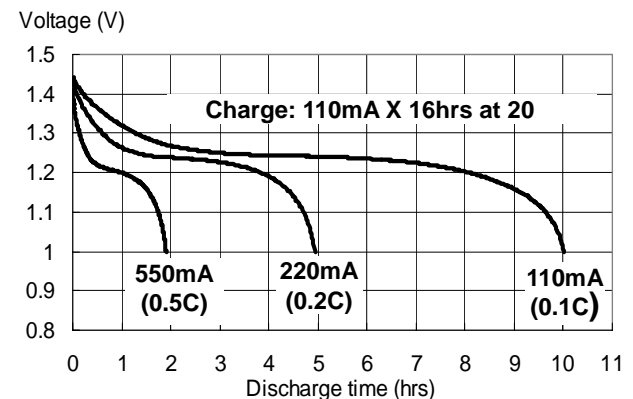

Charge / Discharge efficiency Vs. temp.

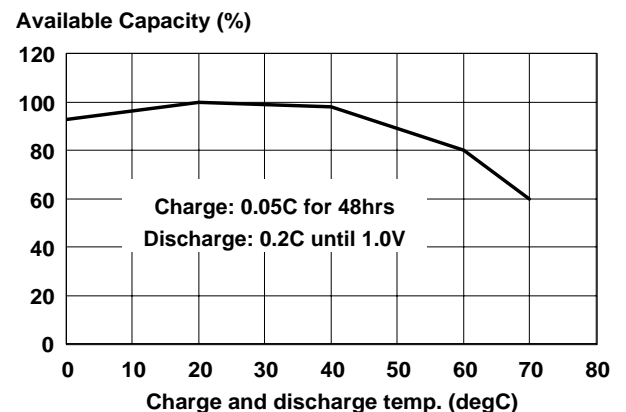

The information (subject to change without prior notice) contained in this document is for reference only and should not be used as a basis for product guarantee or warranty. For applications other than those described here, please consult your nearest GP Sales and Marketing Office or Distributors.